

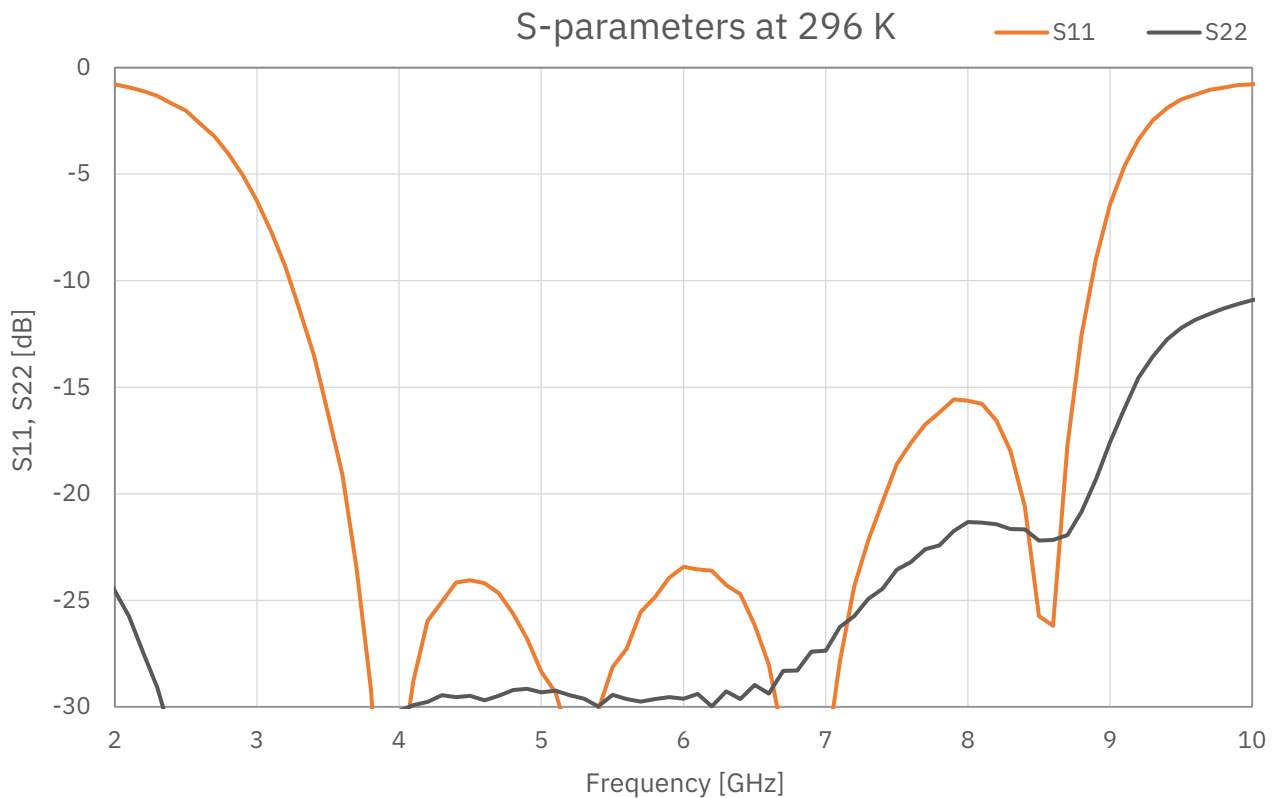

Measured data,  $T_{amb} = 296\text{ K}$

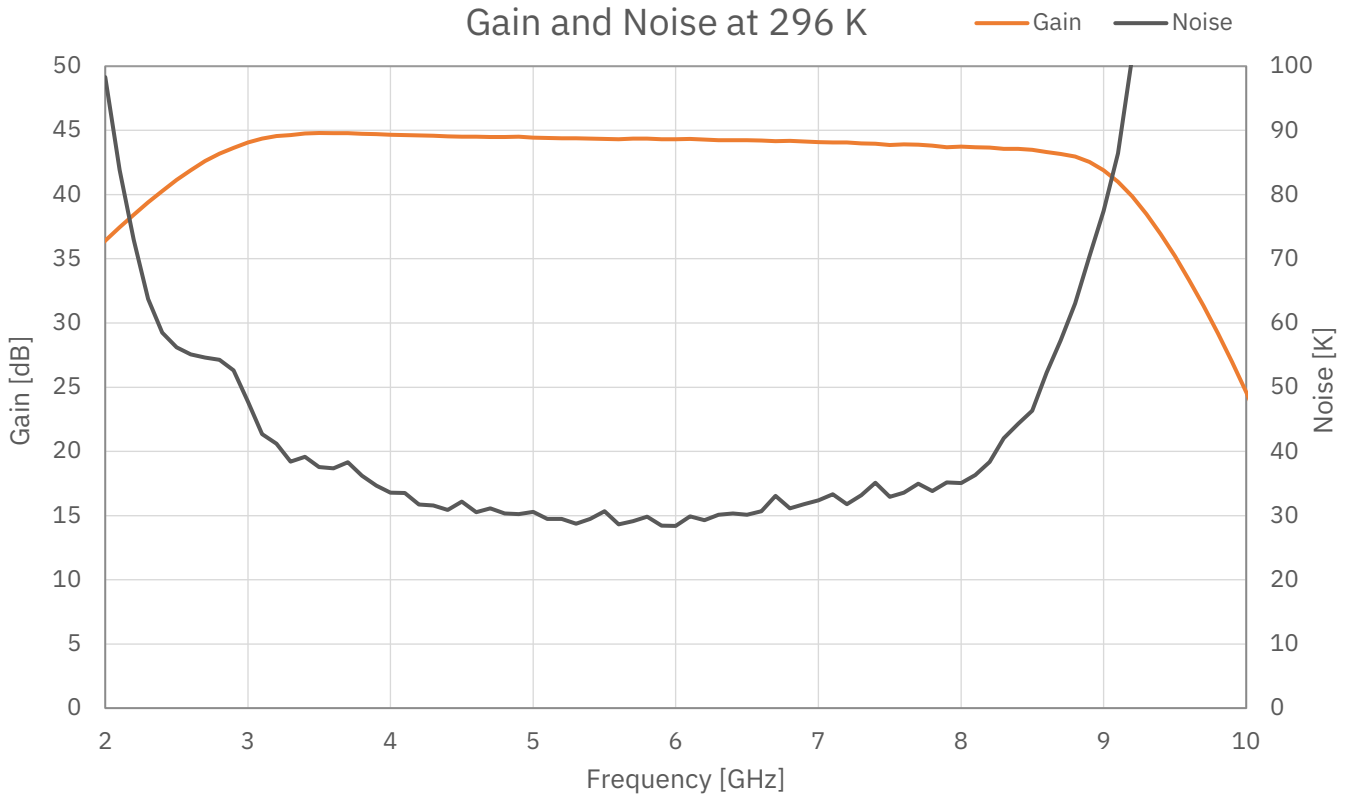

Measured data,  $T_{amb} = 5\text{ K}$

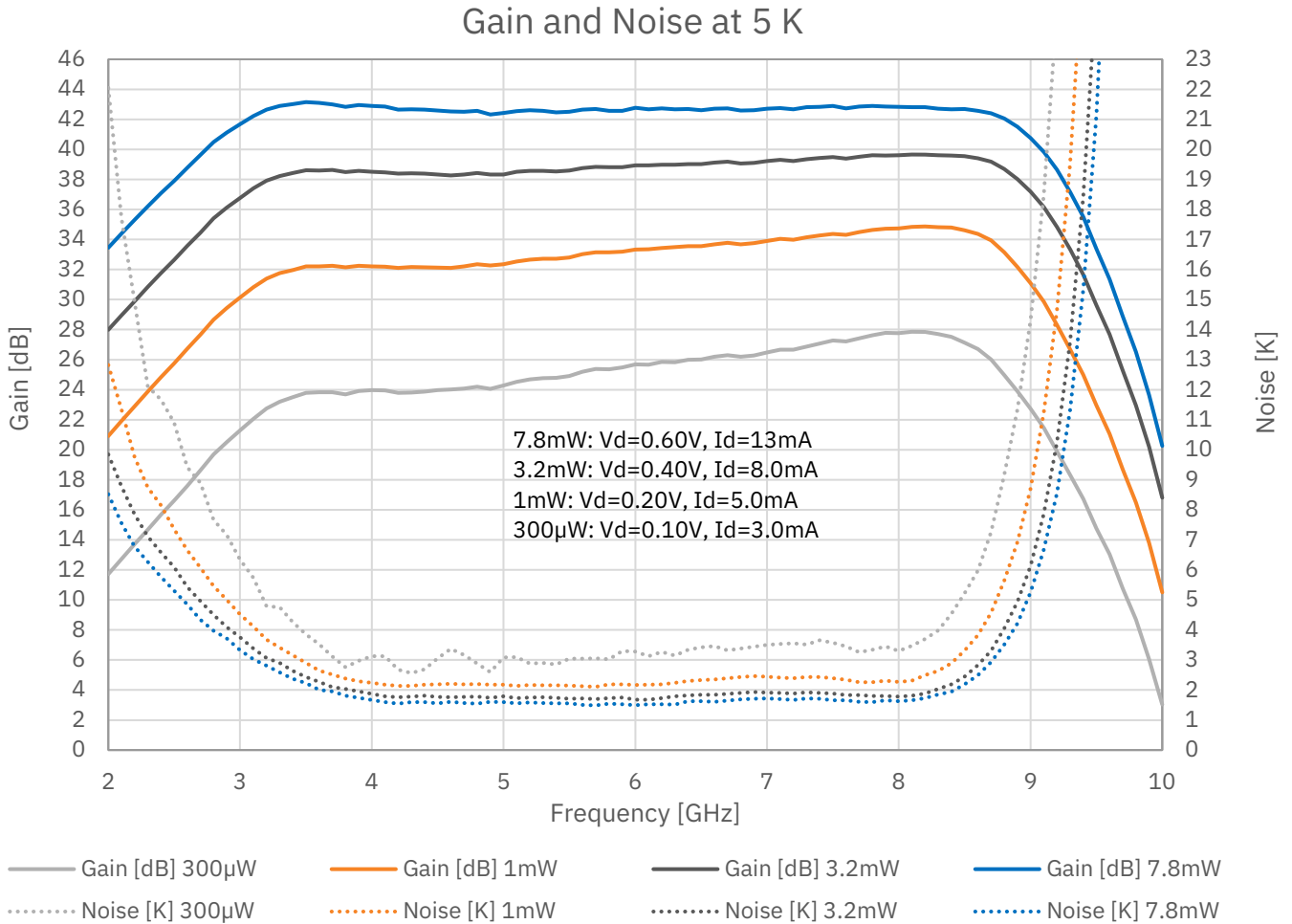

\* Test report submitted with each delivered LNA might vary slightly from this datasheet due to the G3PO to SMA adaptors used in our test systems not being corrected for.

Measured data,  $T_{amb} = 5\text{ K}$

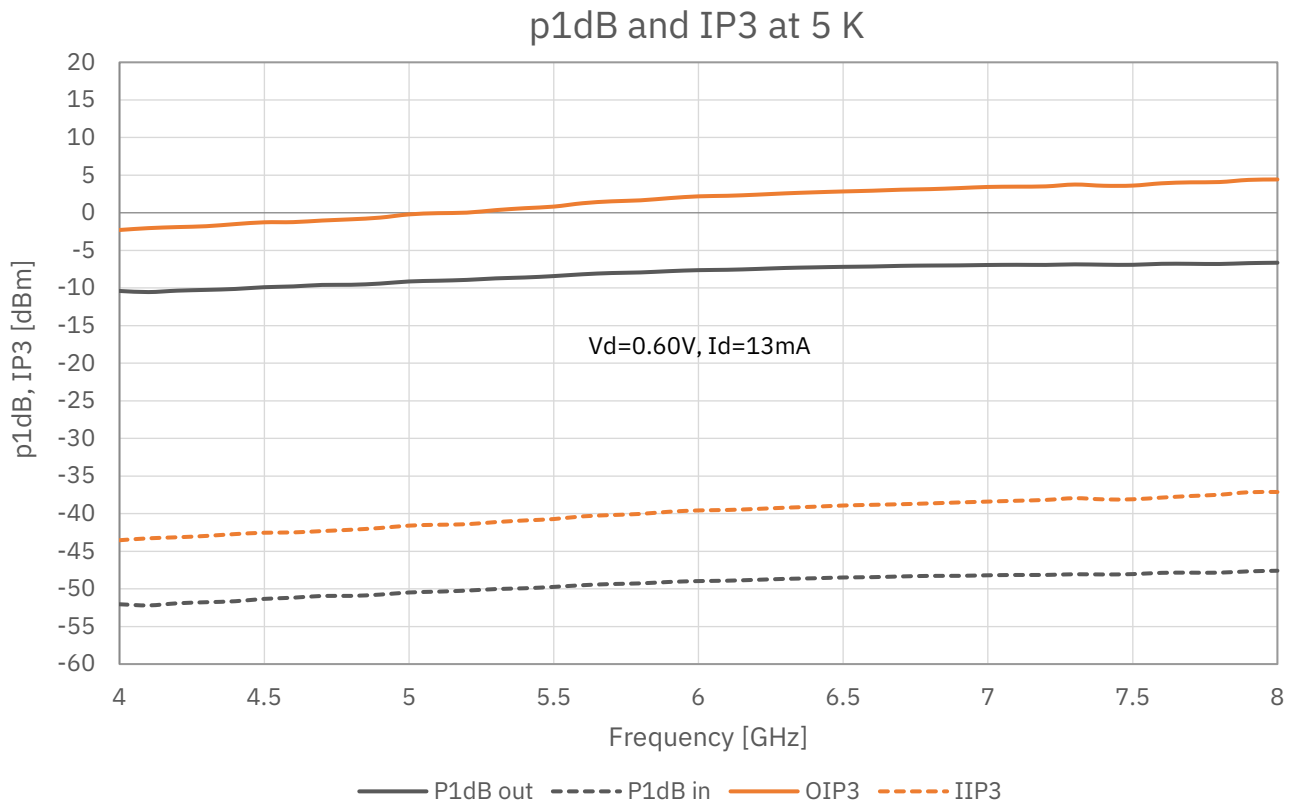

## Dimensions and wiring

Units: mm

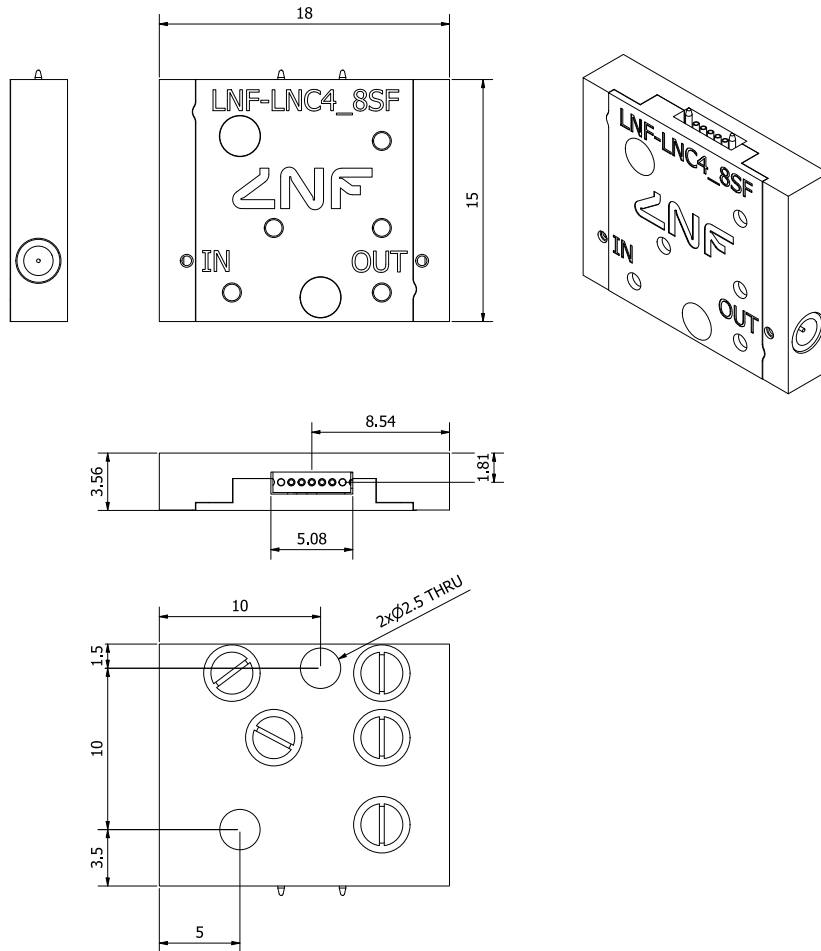

5-pin strip connector seen from outside the LNA (engraved text upward)

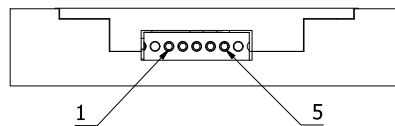

Pin	Function	Wire color
1	GND	Black
2	Vd	Brown
3	Vg	Red
4	NC	Orange
5	NC	Yellow

---

## Biasing procedure

For safe operation of the LNA, please carefully follow the instructions below. Always honor the maximum ratings stated in the datasheet.

### A. With constant current supply, e.g. LNF-PS\_3, LNF-PS3b and LNF-PS\_EU2

Power up:

1. Switch on the power supply
2. Double check that  $V_d$  is set to the nominal voltage in the datasheet
3. Connect the LNA's RF input and output to your grounded test set-up
4. Connect the power supply to the LNA
5. Check that the measured  $I_{ds}$  is equal to the nominal value in this datasheet. Tune to the correct value if necessary.
6. Before starting a cool down, make sure that the power supply is set to the stated values at 5K. Do not cool down with the power supply set to the room temperature values.

Power down:

1. Disconnect the power supply from the LNA
2. Switch off the power supply

### B. With constant voltage supply, e.g. LNF-PS\_1

Power up:

1. Switch on the power supply
2. Set  $V_d$  and  $V_g$  to the nominal voltages stated in this datasheet
3. Connect the LNA's RF input and output to your grounded test set-up
4. Connect the power supply to the LNA
5. Fine tune  $V_g$  to get the nominal  $I_{ds}$  stated in this datasheet. The actual  $V_g$  can deviate a bit from the value in the datasheet depending on ground wire resistance in your set-up.
6. Before starting a cool down, make sure that the power supply is set to the stated values at 5K. Do not cool down with the power supply set to the room temperature values.

Power down:

1. Disconnect the power supply from the LNA
2. Switch off the power supply